Table of Contents

Subject	Page
M Engines - S54B32	2
Objectives of The Module	2
Purpose of The System	3
Technical Data	4
Components	
Engine Block	5
Crankshaft and Bearings	5
Connecting Rods and Bearings	7
Pistons and Rings	8
Oil Circuit Flow	9
Oil Pump.	10
Crankcase Ventilation.	11
Cylinder Head.	12
Coolant Circuit Flow.	13
Camshafts.	14
Valve Train.	16
VANOS.	19
Intake Air System.	25
Fuel Supply.	26
Ignition Coils.	26
Clutch.	27
Exhaust System.	27
Review Questions.	28

M ENGINES

Model: E46 M3, E46 M3 Convertible, M roadster, M coupé

Engine: S54B32

Production Date: 2001 MY to Present

Objectives of The Module

After Completing this module, you will be able to:

- Perform a valve adjustment.
- Identify camshaft markings and correct "timing".
- Explain the VANOS operation.
- Identify piston markings for correct installation.
- Explain the oil flow circuit.
- Understand the oil pump operation.
- Identify the crankcase ventilation components.
- Explain the coolant circuit flow.
- Distinguish the differences between the intake and exhaust valves.
- Identify the intake air system components.
- Identify the S54 fuel injectors and ignition coils.

S54B32 Engine

Purpose of The System

The S54B32 engine is an in-line 6 cylinder power plant. This 3246 ccm displacement engine is used worldwide. The engine designation is:

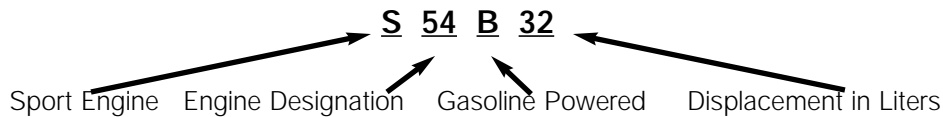

The S54 engine design provides:

1. Everyday Driveability	5. Economic Operation
2. Reduction in Weight of Engine Components	6. Increased Output (to previous M3)
3. Environmental Comparability	7. High Performance
4. Greater Speed Range	8. EDR (Electronic Throttle)

The S54B32 is a 4-valve per cylinder dual VANOS naturally aspirated engine with high torque and high-rev concepts. High torque is developed by a large volume engine at low engine rpm and a long total gear ratio. High-rev is achieved with a small displacement "lightweight" (internal components) engine and short total gear ratio. This powertrain provides the best of both worlds by using a 3.2 Liter in-line 6 cylinder configuration coupled to a 6 speed manual transmission.

Power Output for the E46 M3:

1. 333 hp at 7900 rpm
2. 355 Nm of Torque at 4900 rpm

Power Output for the M roadster and M coupé:

1. 315 hp at 7900 rpm
2. 340 Nm of Torque at 4900 rpm



114100001.jpg

Technical Data

Engine Management	MS S54
Effective Displacement (CCM) Design / Valve Per Cylinder	3246 in-line 6 / 4
Bore / Stroke (mm)	87 / 91
Maximum Engine RPM	8000
Power Output (bhp/rpm) M3 / M roadster - M coupé	333 / 315 bhp @ 7900 rpm
Weight-to-Power Ratio (DIN) kg per KW-kg per bhp	5.93kg/kw-4.36kg / bhp
US Torque (Nm/rpm) M3 / M roadster - M coupe	355 / 340 Nm @ 4900 rpm
Compression Ratio	11.5 : 1
Fuel	Premium Unleaded
Valve Diameter	
Intake / Exhaust (mm)	35 / 30.5
Stem - Intake / Exhaust (mm)	6.0 / 6.0
Valve Lift	
Intake / Exhaust (mm)	12 / 12
Valve Clearance (Adjustment < 35° C Engine Temperature)	
Intake (mm)	0.18 - 0.23
Exhaust (mm)	0.28 - 0.33
Camshaft Spread Angle	
Intake (degrees)	70 - 130
Exhaust (degrees)	83 - 128
US Emission Compliance	LEV

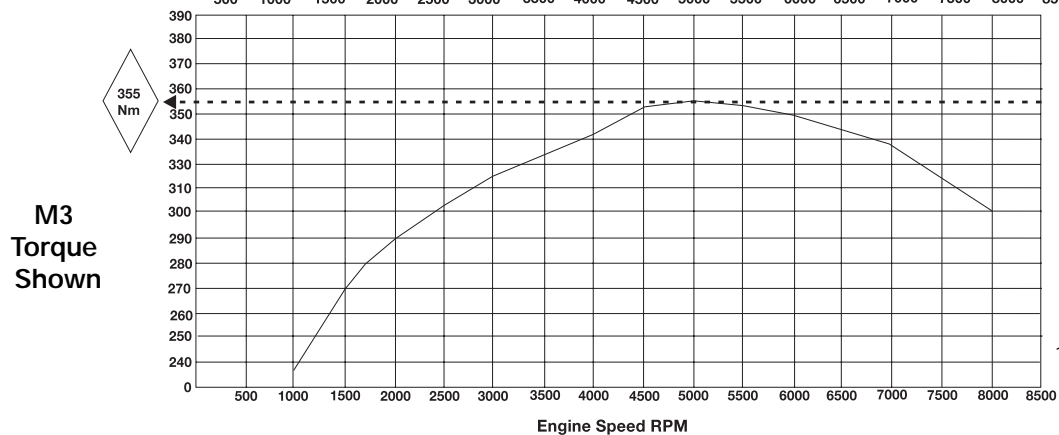
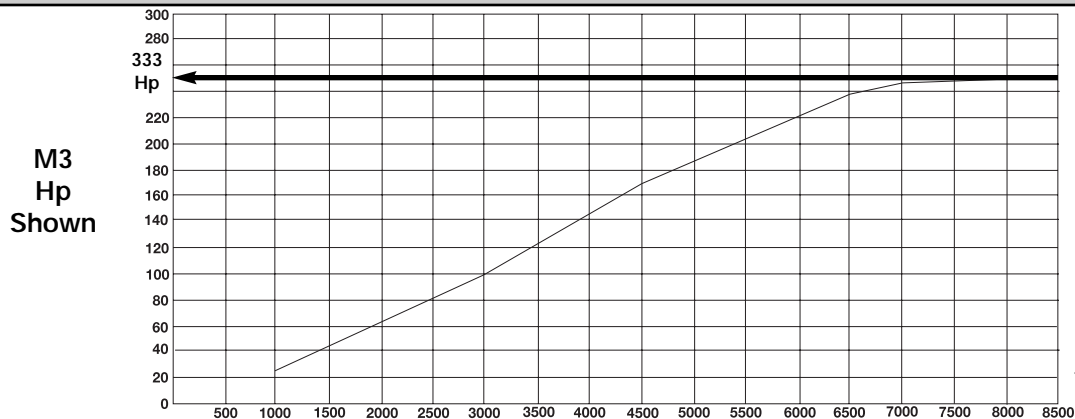

System Components

Engine Block: The S54 engine block is cast iron in order to absorb the high forces produced by the crankshaft (combustion pressure and high engine rpm).

The engine block has cast provisions for 3 Knock Sensors and the Crankshaft Position/RPM Sensor (on the intake side).

The cylinder bores are 87 mm in diameter and are spaced 91 mm on center.

The “bare” block weighs approximately 105 lbs. (48 kg).



11410004.jpg

Crankshaft and Bearings: The S54 crankshaft is forged steel with 12 counterweights and a 91 mm stroke. The crankshaft is supported by 7 (60 mm diameter) main bearings with 49 mm diameter connecting rod journals.

The “thrust” bearing is a multi-piece shell assembled as a unit and is located on the number 6 main journal of the crankshaft.

Bearing Clearance:

- | |
|-------------------------------------|
| 1. Main 0.02 - 0.05 mm |
| 2. Thrust (end play) 0.08 - 0.16 mm |

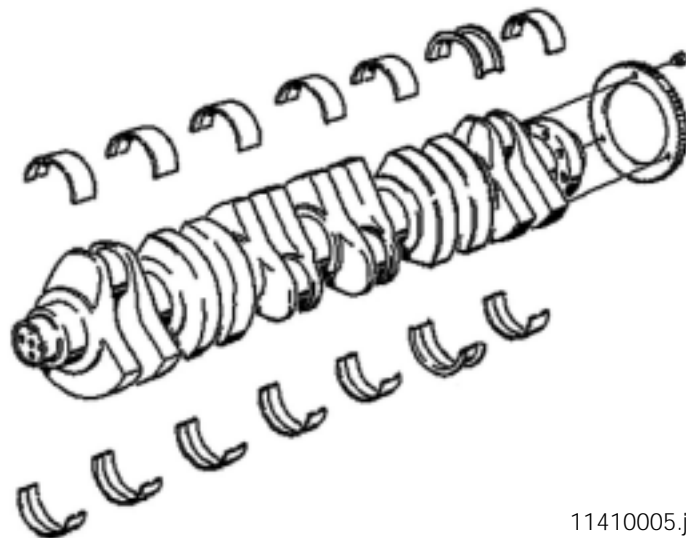

11410005.jpg

The impulse wheel is bolted to the number 6 connecting rod journal counterweight.

The S54 impulse wheel is bolted directly to the crankshaft providing accurate:

1.	Crankshaft Position - Reference
2.	Engine RPM
3.	Smooth Running Measurement
4.	Misfire Detection

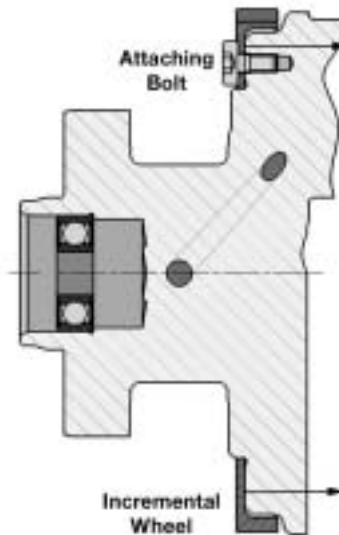

11410006.bmp

The Crankshaft Position/RPM Sensor is mounted on the rear of the engine block (below the intake manifold).

The sensor protrudes through the engine block (arrow) to scan the impulse wheel gear teeth.

The cast sensor mounting is shown from the rear view of the engine.

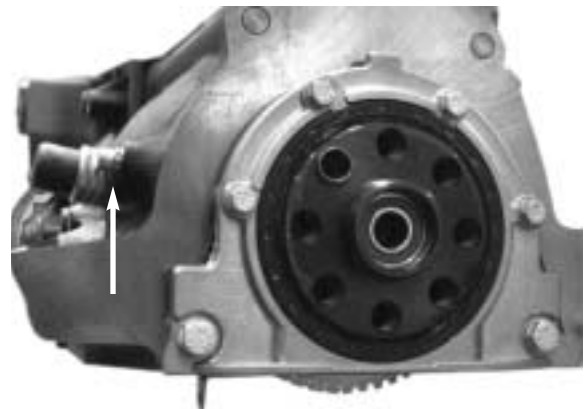

11410007.jpg

The torsional vibration damper is specifically designed for the higher engine rpm.

The damper is secured by 4 bolts which must be angle torqued (refer to Repair Instructions and Technical Data).

Note the installation location for the crankshaft position locating tool (arrow).



11410008.jpg

Connecting Rods and Bearings: The S54 uses reinforced forged steel “cracked” connecting rods:

1. Length = 139 mm
2. Small End (Integrated Bushing) Diameter = 21 mm
3. Large End Diameter = 49 mm



11410009.jpg

The “cracked” connecting rod refers to the cap which is split off leaving rough surfaces on both the cap and the rod.

Centering of the cap on the rod is carried out through the structure of the split which eliminates the alignment sleeves. Pairing codes are stamped into the rod to ensure proper installation of the cap.

The S54 connecting rods are weight-optimized (+/- 4 grams). Only one set of connecting rods (the same weight class) is available to maintain balance.

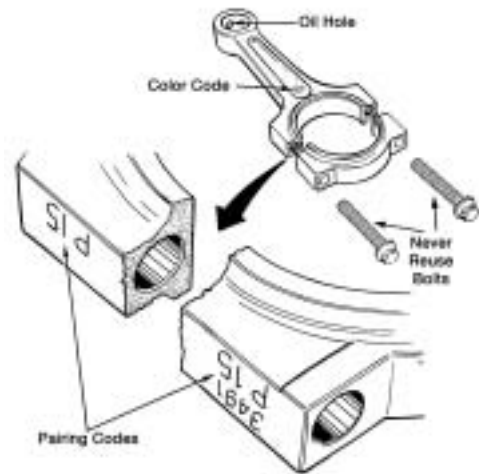

11410000.bmp

The connecting rod bolts must be angle torqued (refer to Repair Instructions and Technical Data). **The bolts can not be replaced separately**, if damaged; the connecting rod must be replaced (supplied with new bolts).

The S54 connecting rod bearings use end mounted locating tabs.



11410010.bmp

Notes: _____

Pistons and Piston Rings: The S54 uses graphite coated cast aluminum (full slipper skirt) pistons with valve recesses.

The piston diameter is 86.965 mm, weighs approximately 470 grams with a compression ratio of 11.5:1.

Install the pistons with the arrow pointing towards the front of the engine.

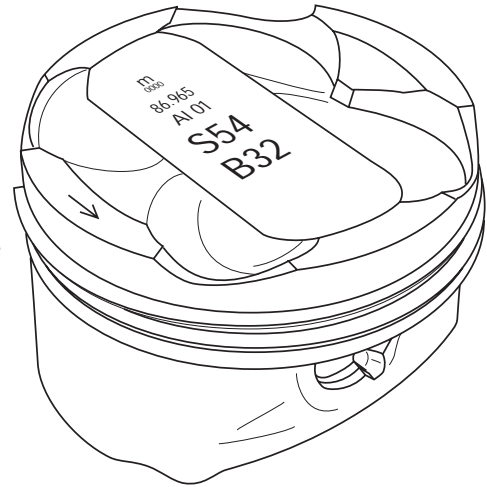

11410065.eps

Piston Rings:

1. Compression Ring 1 = 1.2 mm Height
2. Compression Ring 2 = Stepped Face 1.5 mm Height
3. Oil Control Ring = Beveled, Spring Loaded 2 mm Height

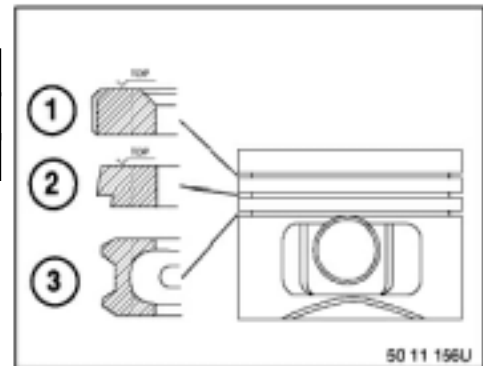

A Special Tool (ring compressor) is required to install the pistons.

The pistons are cooled by oil spray nozzles that are bolted into the crankcase.

The nozzles are “tapped” into the main oil gallery and delivers a constant oil spray to the underside of the pistons.

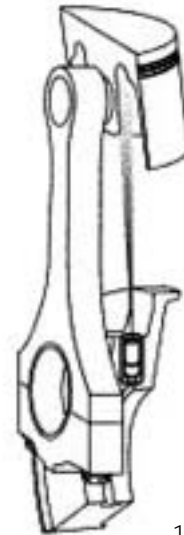

11410011.bmp

The wrist pins are 21 mm in diameter and have tapered ends (inside diameter) for weight reduction.



11410066.eps

Oil Circuit Flow:

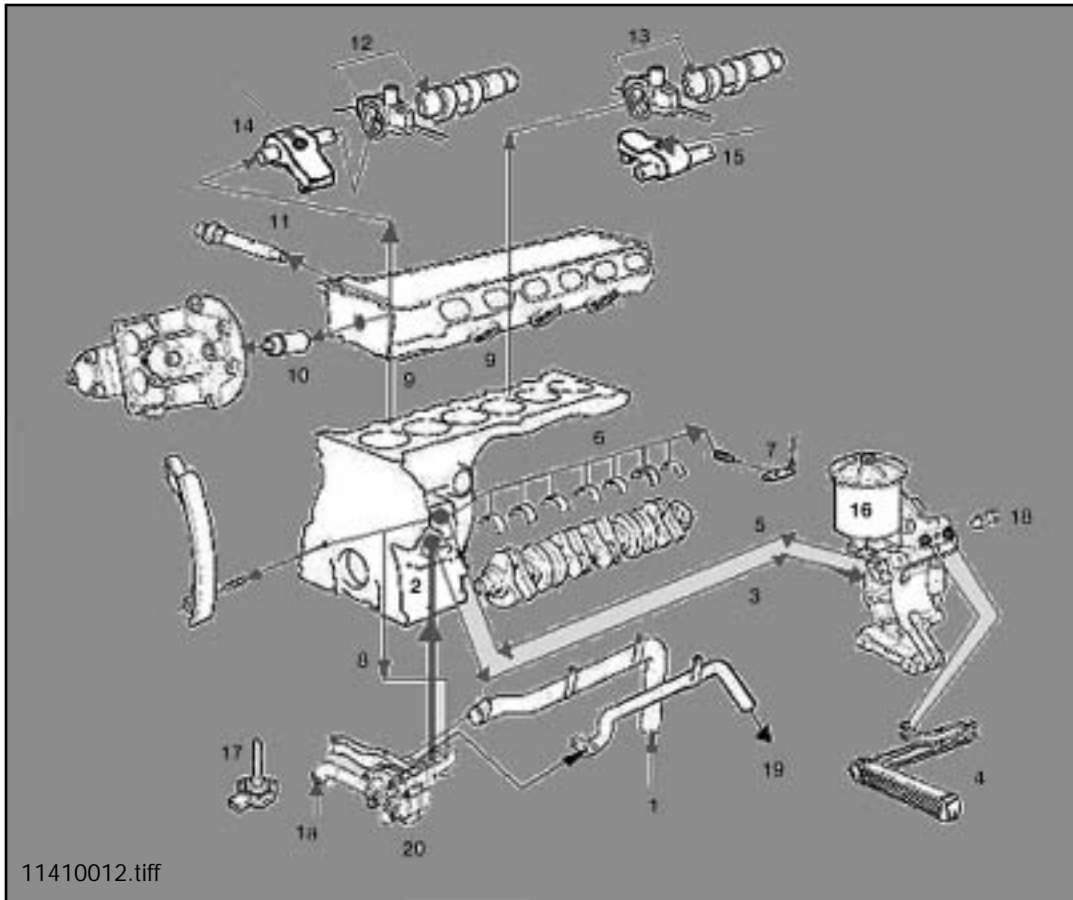

1.	Oil Pump Intake (rear of pan)	17.	Thermal Oil Level Sensor
1a.	Oil Pump Intake (front of Pan)	18.	Oil Pressure Switch
2.	Supply to Block	19.	Oil Return Flow Line
3.	Supply to Oil Filter / Cooler	20.	Oil Pump (two stage)
4.	Oil Cooler (flow controlled by 95m° C thermostat in oil filter housing)		
5.	Filtered Oil Return to Main Gallery		
6.	Main Oil Gallery (crankshaft, connecting rods, spray nozzles)		
7.	Spray Nozzles for Pistons		
8.	Oil Pressure Control (back to valve in Pump)		
9.	Supply to Cylinder Head		
10.	Supply to VANOS Pressure Reducer Valve		
11.	Supply to Timing Chain Tensioner		
12.	Exhaust Camshaft Bearings		
13.	Intake Camshaft Bearings		
14.	Exhaust Valve Finger with Oil Collector Hole		
15.	Intake Valve Finger with Oil Collector Hole		
16.	Oil Filter Housing		

The recommended oil for the S54 is CASTROL TWS MOTORSPORT SAE 10W-60 or CASTROL FORMULA RS 10W-60 SYNTHETIC OIL - PN 07 51 0 009 420 (refer to SIB # 00 02 00 and 11 06 01). Oil Capacity: Refer to Technical Data or the Oil Capacity Chart found in the Service Information Bulletin.

Oil Pump: The S54 oil pump is two stage, supply and scavenge. The pump is driven by the crankshaft with a single row chain.

The oil pump has two separate chambers, the scavenge chamber (1) draws oil from the pickup at the front of the oil pan. The oil is transferred from the pump through a small pipe to the main sump at the rear of the oil pan (2).

The supply chamber (3) draws oil from the main sump through a large pipe (4) to supply oil to the main gallery. The main gallery circuit returns to the pump housing which contains the oil pressure control piston.

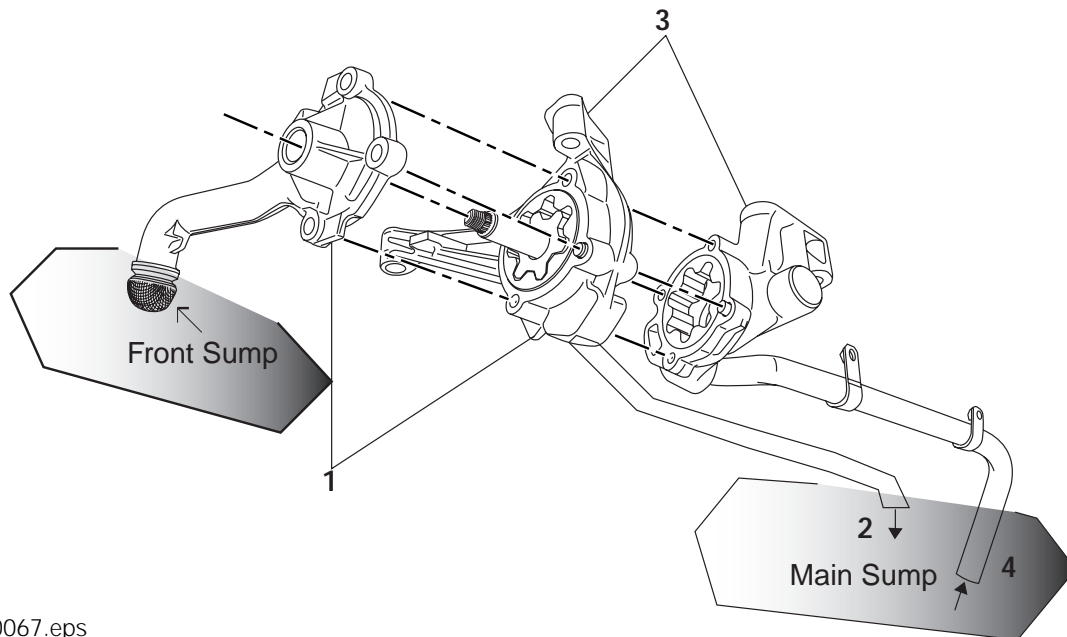

11410067.eps

The oil pressure is tested at the oil filter housing using the Special Tool #90 88 6 114 390 (adapting retainer bolt and pressure gauge as shown in the Repair Instructions).

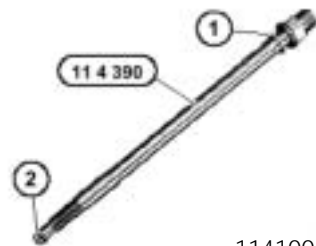

11410016-1

The adapter retainer bolt replaces the oil filter housing cover retaining bolt and provides an adapter fitting for the oil pressure gauge.



11410016.tiff

Crankcase Ventilation: The S54 features a non-pressurized sealed crankcase ventilation system for the blow-by vapors.

1. Intake Manifold
2. Oil Pan
3. Oil Separator (Labyrinth)
4. Cylinder Head Cover
5. Drainback Tube
6. Crankcase Vapor Inlet
7. Crankcase Vapor Outlet (To Intake Manifold)
8. Condensate Return to Oil Pan (With Check Valve)
9. Condensate Return To Oil Pan

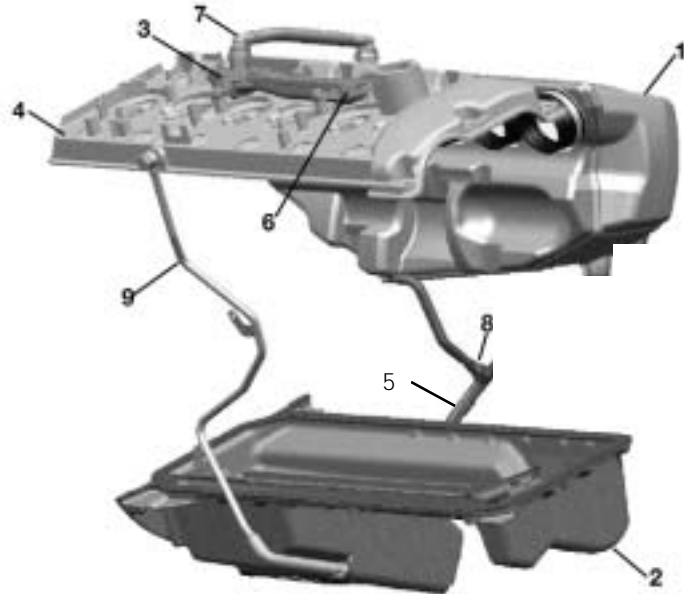

11410013.jpg

The crankcase blow-by vapors are “purged” by intake manifold vacuum. The vapors are drawn from the cylinder head cover (4) through the inlet of the Oil Separator (6). The Labyrinth (3) separates the oil from the vapors, and the condensate (oil) returns to the oil pan through the return line (9). The vapors exit the Oil Separator through the outlet hose (7) to the intake manifold to be inducted into the combustion chambers.

When the engine is running, intake manifold vacuum will close the Check Valve in the return line (8). When the engine is not running, the Check Valve will open. This allows any condensation (oil) that have collected in the intake manifold to drain back to the oil pan through the dipstick tube.

The cylinder head cover is sealed by a perimeter seal, spark plug port seals and sealing washers under the retaining bolts.

These individual seals must all be properly installed to prevent oil and vacuum leaks.

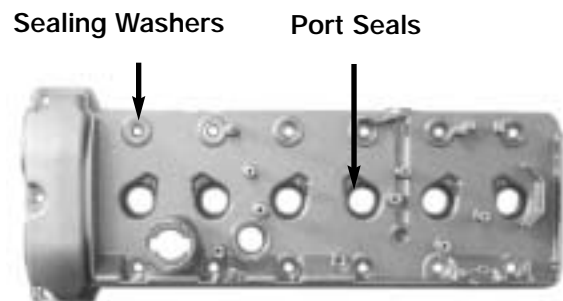

11410016.tiff

Cylinder Head: The S54 features an aluminum cross-flow cylinder head designed as a single component that houses the camshafts and valve train.

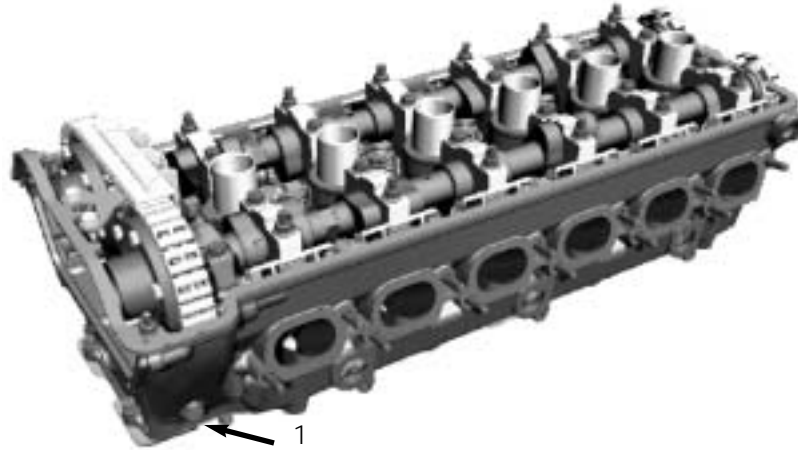

11410018.tiff



11410015.jpg

The combustion chamber reveals the 4 valve per cylinder arrangement and the optimized (flow enhanced) intake and exhaust ports. The spark plugs are centrally located in the combustion area for the most effective power and reduced emission outputs.

To remove the cylinder head, the camshafts must first be removed to access the cylinder head bolts (refer to the Repair Instructions). ***The timing chain guide rail bolt must also be removed (upper picture #1) and the special sealing washer must be replaced.***

To pressure test the cylinder head, a Special Tool (Pressure Tester Adapter Kit) is required. ***Cylinder head machining is not permitted.***

Coolant Circuit Flow:

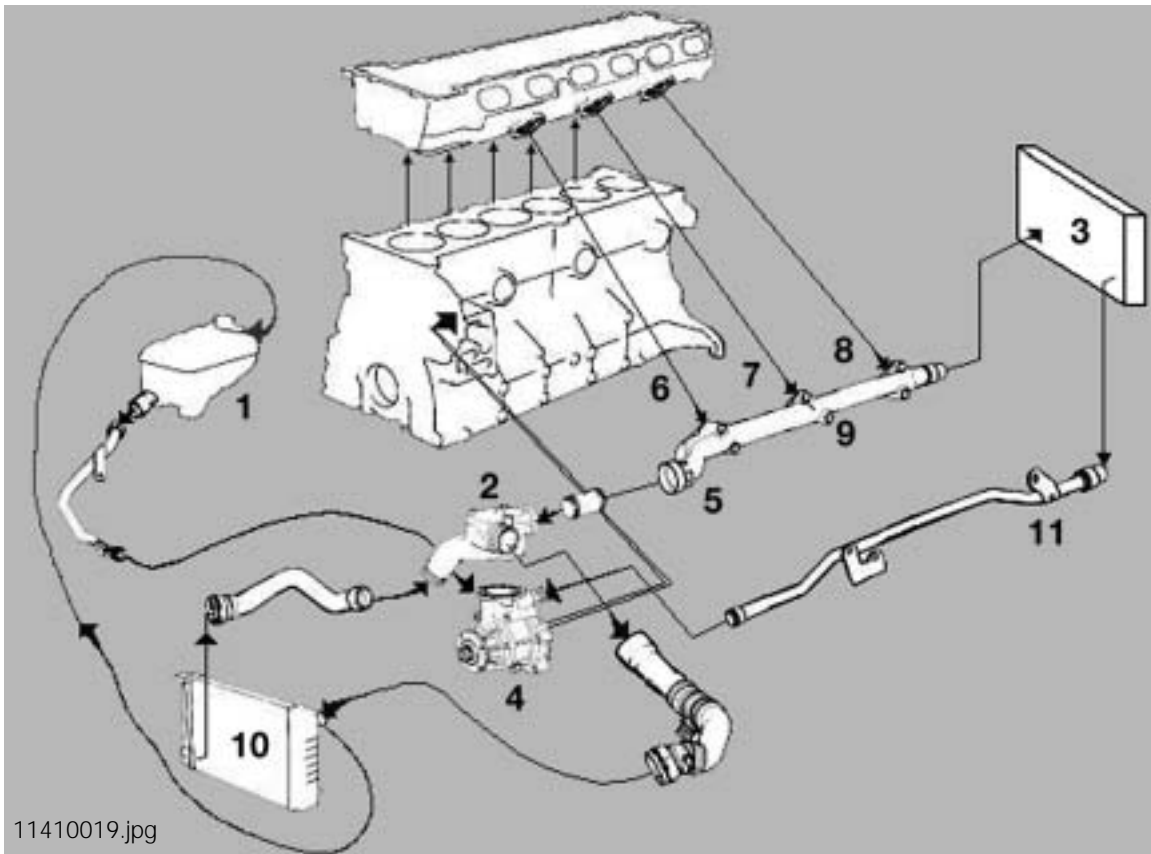

1.	Coolant Reservoir (2 bar system)
2.	Thermostat Housing (80° C thermostat)
3.	Heater Core
4.	Water Pump
5.	Coolant Temperature Sensor
6,7,8	Coolant Outlet (from cross-flow cylinder head)
9.	Coolant Return Pipe
10.	Radiator
11.	Coolant Return Line (from heater core)

The S54 uses a high efficiency water pump (4) to enhance the Cross Flow cylinder head design.

The cross-flow design ensures even temperature distribution through out the cylinder head. The coolant flows from the engine block on the exhaust side into the cylinder head.

The coolant flows through (across) the cylinder head and exits at the intake side through three outlets (6,7,8). The coolant is routed through the Return Pipe (9) to the thermostat housing (2).

Camshaft Drive: The camshafts are driven by the crankshaft using a double-roller timing chain.

1.	Crankshaft Sprocket
2.	Aluminum Guide Rail
3.	Intake Camshaft Sprocket
4.	Exhaust Camshaft Sprocket
5.	Short Tension Rail
6.	Long Tension Rail (with 3 Lubrication Holes)
7.	Hydraulic Tensioner

The chain is routed from the crankshaft over a guide rail to the intake and exhaust camshaft sprockets. A two piece hydraulically tensioned guide rail lubricates (three oil outlets provided) and "self adjusts" the chain.

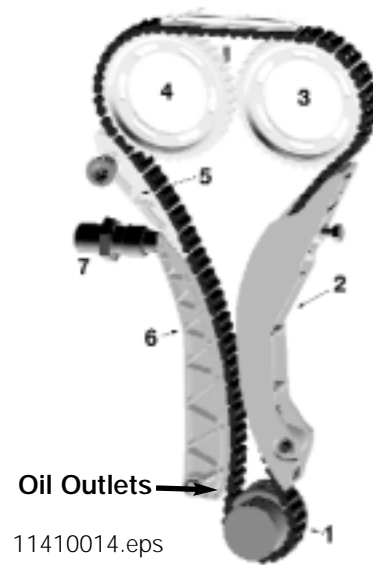

Camshafts: The S54 cast iron overhead camshafts are hollow and are strengthened by heat treating the journals and cam lobes. The duration and lift (12 mm) of the lobes are the same on both camshafts.

The camshafts are not interchangeable, therefore they should be marked before disassembly.

The camshaft lobes have oil grooves (shown by arrows to the right) that provide lubrication from the camshaft journals to the lobes and the valve fingers.

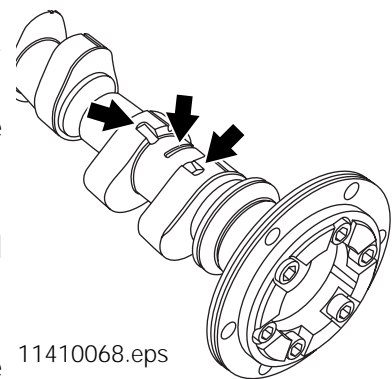

The camshafts must be removed and installed with the press fixture (Special Tool #90 88 6 114 380 as shown in the Repair Instructions).

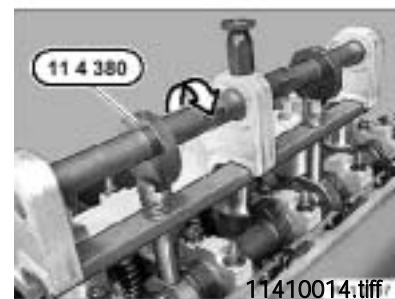

The camshafts are "timed" with the bridged location tool (pinned into camshaft as shown in the Repair Instructions).



The VANOS enhanced camshaft spread angles are:

Intake (E) 70° - 130°
Exhaust (A) 83° - 128°

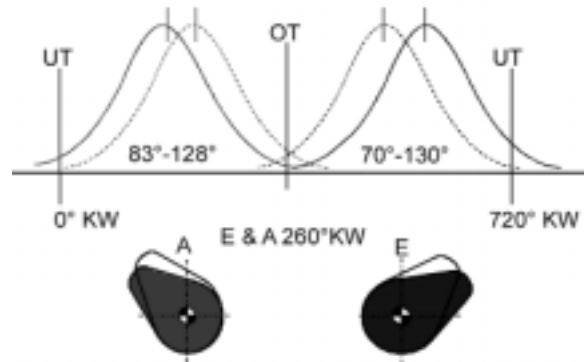

11410021.bmp

The camshafts are supported by 7 bearing journals machined into the cylinder head.

The bearing journal caps are location specific. The markings are:

- | | |
|----|-----------------------------|
| 1. | E=Intake Side Number 2 - 7 |
| 2. | A=Exhaust Side Number 2 - 7 |



11410018.jpg

The first camshaft bearing journal also serves as the thrust bearing (unmarked).

This two-piece bearing flange is forged to support VANOS axial loads.

The thrust bearing flange is bolted to the face of the cylinder head. *This component is not separately available because the journals are machined with the cylinder head.*



11410021.jpg

An impulse wheel is mounted on the end of each camshaft for position detection. The impulse wheels are secured by a removable bolt (1).

The intake camshaft impulse wheel has 6 lugs and the exhaust camshaft impulse wheel has 7 lugs (with gap).

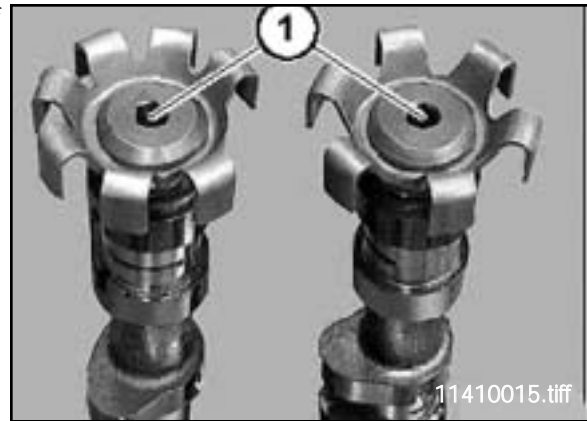

Valve Train: The camshaft lobe actuates the valve finger (rocker arm) which rotates on a finger (rocker) shaft. The valve finger is secured by a spring clip and contacts the valve clearance shim (9 mm diameter) to open the valve.

The adjustable valve clearance set by various shim thickness is:

1.	Intake 0.18 - 0.23mm
2.	Exhaust 0.28-0.33mm
*	Set With Engine Temperature < 35° C

Two feeler gages and a holder with a magnetic tip (Special Tools) are required to adjust the valve clearance. The cam lobe must be rotated away from the valve finger for maximum clearance.



To access the valve clearance shim, remove the finger securing clip. Slide the finger away from the valve spring to expose the shim. Use the magnetic tip holder to extract the shim.

The shims (shown by the arrow to the right) are available in sizes from 1.72 to 2.52 mm at 0.04 mm increments.

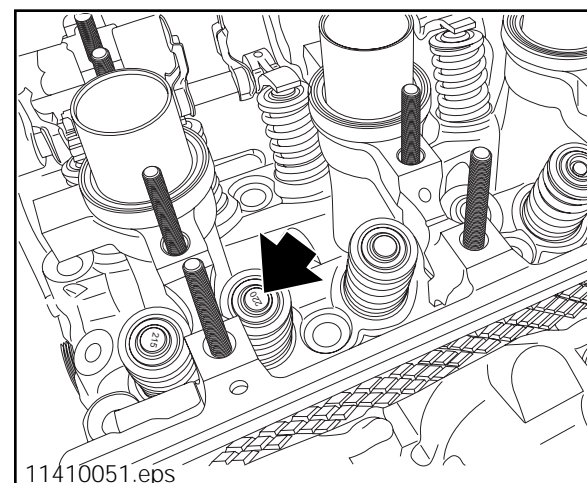

The finger (rocker) shafts are secured with locating bolts (one per side) at the back of the cylinder head (1).



Remove the threaded access bolts (1) from the rear face of the cylinder head and push the shafts through.



Both finger shafts are hollow, the exhaust shaft is unique because it supplies oil to the camshaft bearing journals.

The exhaust shaft receives oil from the main oil gallery through the transfer hole (arrow).

The intake camshaft is lubricated directly from the main oil gallery.



The valve fingers are identical but must be marked for location when previously used.

Lubrication for the slide contact is provided from the camshafts (lobe grooves) and an inlet hole (arrow) allows lubrication for the finger pivot journal.



Valves and Valve Springs: The intake and exhaust valves are lightweight in design to reduce reciprocating mass. The valve diameter is:

1.	Intake 35 mm
2.	Exhaust 30.5 mm
3.	Stem-Intake / Exhaust 6.0 mm

The exhaust valve stems are sodium filled to enhance cooling.

CAUTION! Consult the Repair Instructions before performing any repairs and for proper disposal of sodium filled valves.



11410028.tiff

The valve spring assembly consists of two progressive tensioned valve springs.

The springs are marked for correct installation due to progressive tensioning (*paint stripes facing down towards cylinder head*).



11410030.tiff

Notes: _____

VANOS

Performance, torque, idle characteristics and exhaust emissions reduction are improved by variable camshaft timing (VANOS).

The S54 engine uses double VANOS to adjust the spread angles of the intake and exhaust camshafts.

This system uses a high pressure (100 Bar) control system that ensures responsive and accurate camshaft adjustments to meet the high performance requirements of the M Engines.

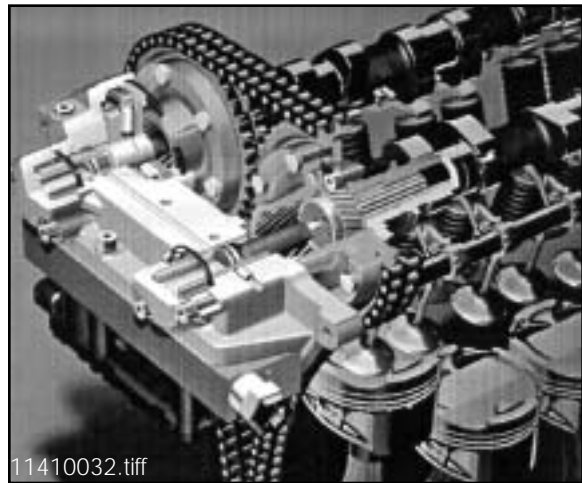

The VANOS unit is mounted directly on the front of the cylinder head.

The VANOS unit contains the hydraulically actuated mechanical drives (1), the electronically controlled oil pressure regulating solenoids (2) and the 100 Bar pressure regulating valve (3).

The back view of the VANOS unit shows the inlet oil supply pressure reducing valve (4) and the radial piston high pressure output pump driven by the exhaust camshaft (5).

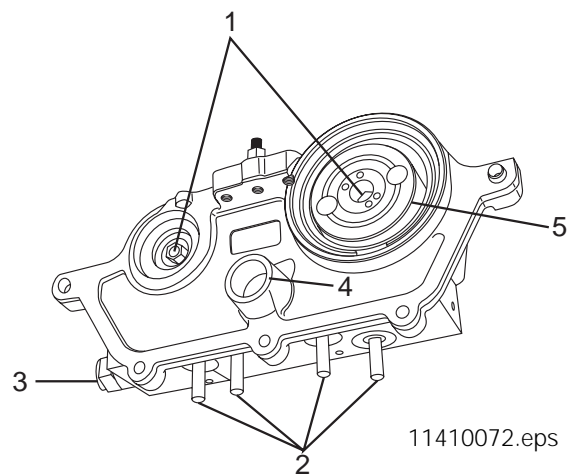

The VANOS solenoid electrical assembly (removed from the VANOS unit) contains four solenoids.

Two solenoids are required for each adjusting piston circuit, one for advancing and one for retarding the camshaft timing. The solenoids are controlled by the ECM.

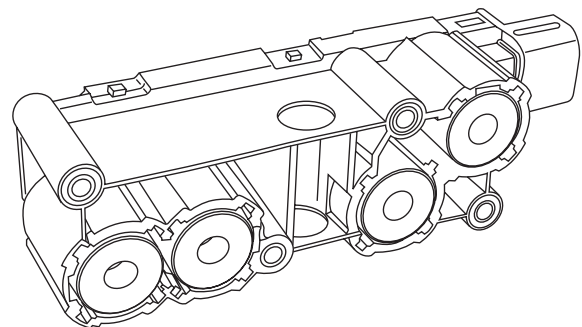

11410073.eps

The adjustment shafts contain two sets of splines that engage with:

- | | |
|----|---|
| 1. | Camshaft Sleeves (Straight Splines) |
| 2. | Chain Driven Sprocket (Helical Splines) |



11410037.jpg

The camshaft sleeves are bolted to the end of the camshafts and engage with the straight spline of the adjustment shaft shown above.

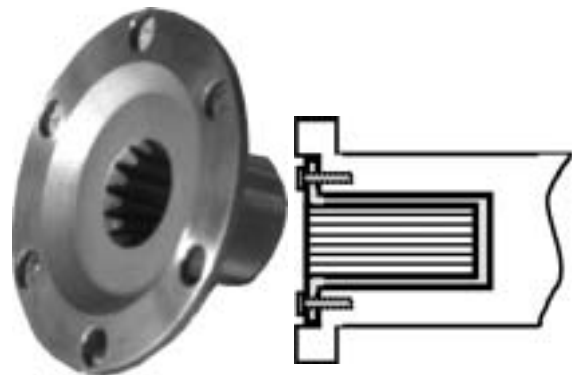

11410074.eps

The chain driven sprocket and spacer sleeve assembly is shown to the right (one assembly per camshaft). The sprocket engages with the helical splines of the adjustment shaft shown above.

The exhaust camshaft sprocket assembly has two drive “lugs” that must be aligned with the radial piston oil pump during installation.

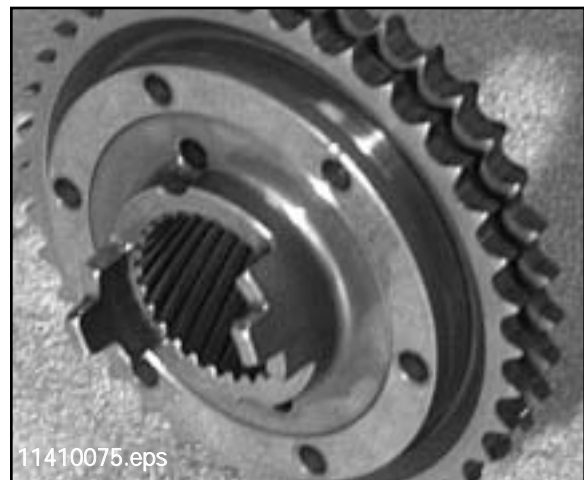

11410075.eps

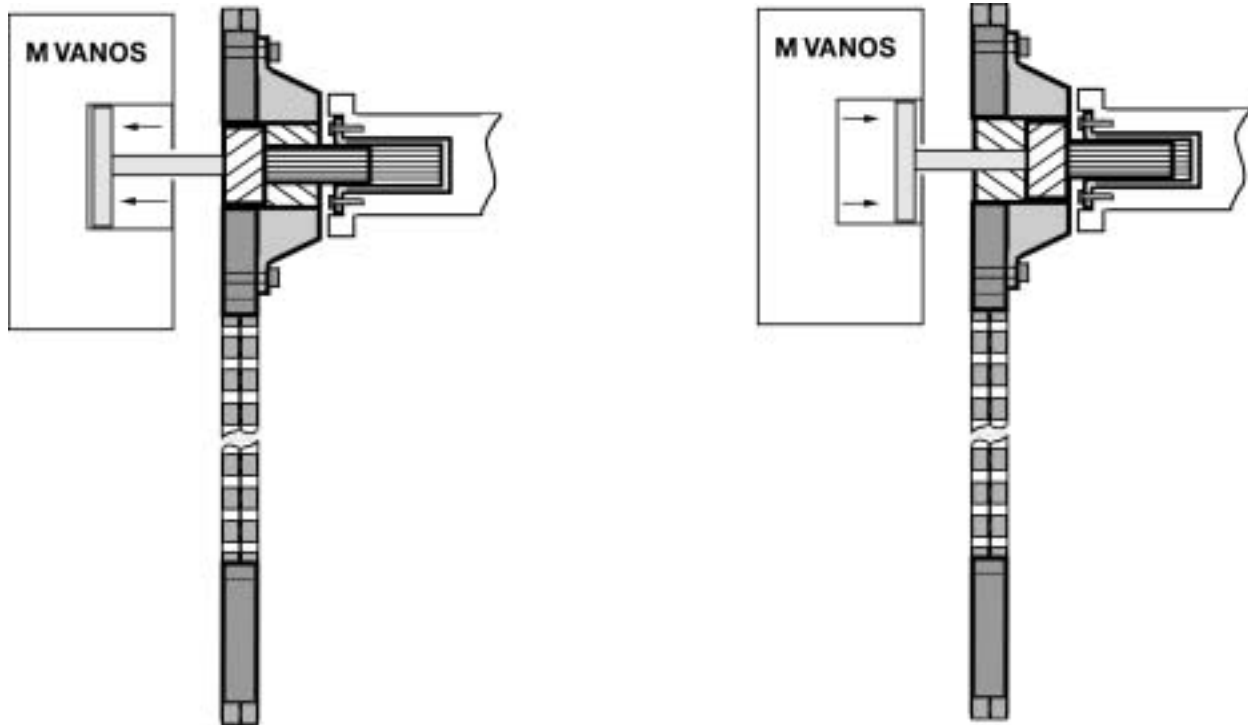

11410039.bmp

VANOS mechanical operation is dependent on oil pressure applied to position the control pistons. The double VANOS camshafts are infinitely adjustable within the mechanical travel limits of the drive gears.

When oil pressure is applied to the control piston, the piston moves causing the splined adjustment shaft to move. The straight splines slide within the camshaft sleeve. The helical splines rotate the camshaft drive sprocket changing the position in relation to the camshaft position which advances/retards the camshaft timing.

The total adjustment range of the intake camshaft is 60°.

The total adjustment range of the exhaust camshaft is 45°

The "default" mechanical stop position without VANOS influence is:

Intake Camshaft = Retarded (130° spread angle)

Exhaust Camshaft = Advance (83° spread angle)

Oil is supplied from the main gallery through the front of cylinder head (arrow) to the inlet pressure reducing valve.

Pressure Reducing Valve: The pressure reducing valve supplies oil to the radial piston high pressure oil pump. It is located between the cylinder head and the VANOS unit.

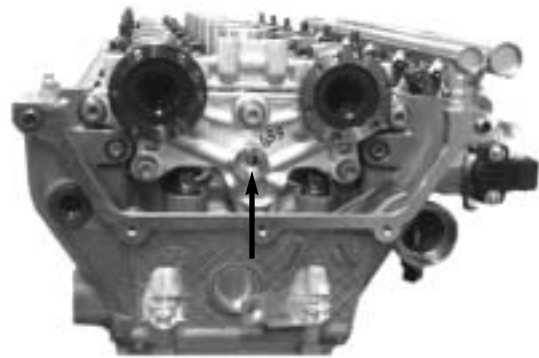

11410042.tiff

The valve ensures the oil pressure supply to the VANOS pump is 0.5 Bar regardless of the varying pressure from the main oil pressure gallery. The pressure reducing valve is pressed into the VANOS unit and secured by an "o-ring".

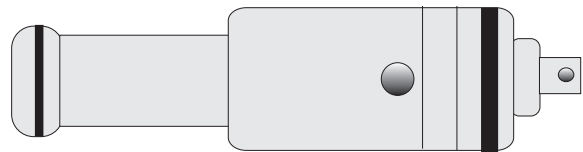

11410080.eps

100 Bar Pressure Regulating Valve: The 100 Bar pressure regulating valve is mounted in the VANOS unit. This valve regulates the pressure produced by the radial piston high pressure oil pump.



11410002.eps

Note: The 100 Bar pressure regulating valve is not adjustable.

VANOS Accumulator: The VANOS accumulator ensures that there is a sufficient volume of oil under pressure to adjust the camshafts under all engine operating conditions.

The accumulator is Nitrogen charged and is located on the exhaust side of the engine behind the A/C compressor. It is connected to the VANOS unit by a high pressure line.



11410076.eps

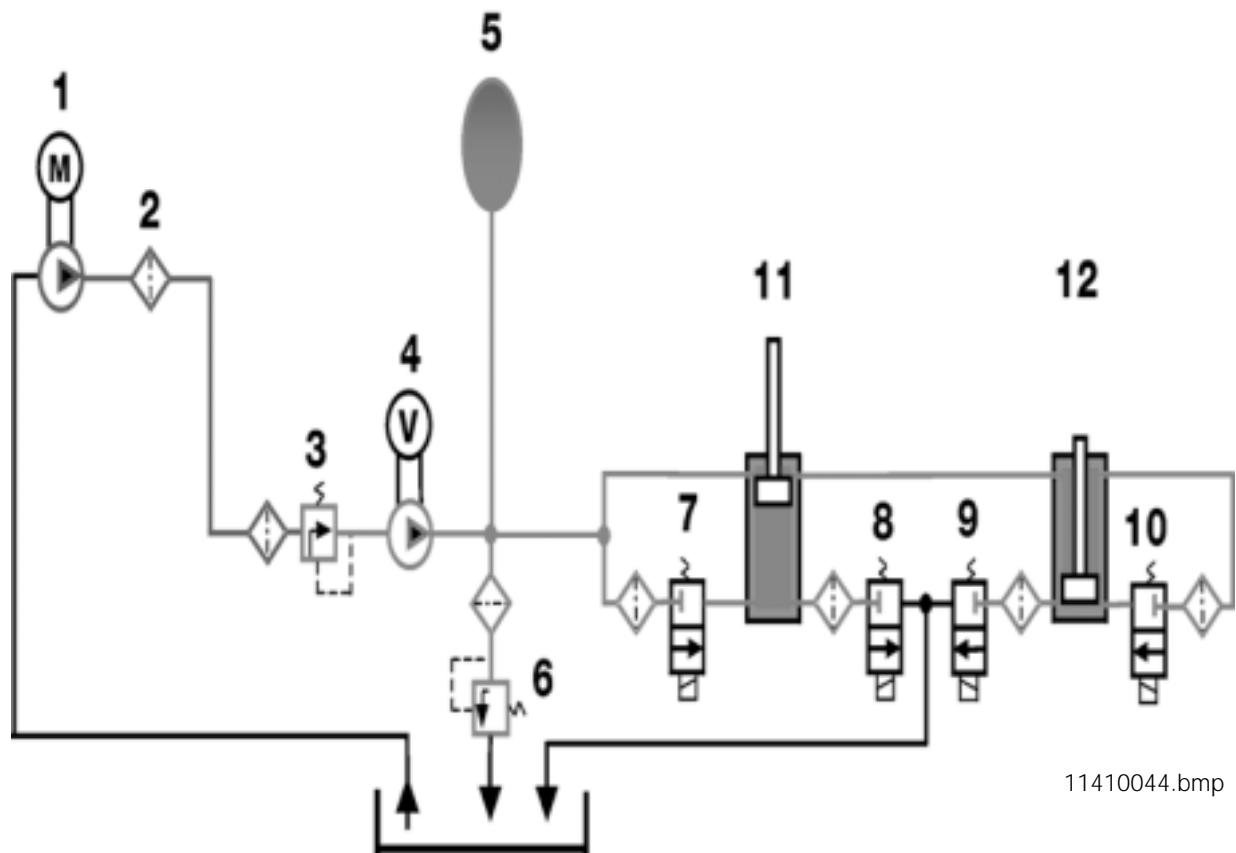

11410044.bmp

1.	Engine Oil Pump	7.	Exhaust Camshaft Inlet Solenoid Valve
2.	Engine Oil Filter	8.	Exhaust Camshaft Outlet Solenoid Valve
3.	Pressure Reducing Valve (0.5 Bar)	9.	Intake Camshaft Outlet Solenoid Valve
4.	VANOS Oil Pump	10.	Intake Camshaft Inlet Solenoid Valve
5.	VANOS Accumulator	11.	Exhaust Camshaft Control Piston (Advance)
6.	100 Bar Pressure Regulating Valve	12.	Intake Camshaft Control Piston (Retard)

VANOS system hydraulic operation:

- When the engine starts, oil from the main engine oil pump is fed under pressure to the pressure reducing valve.
- The oil pressure is dropped to approximately 0.5 Bar and fed to the radial piston high pressure oil pump.
- The pump is driven by the exhaust camshaft and the 100 bar pressure is built up by the pressure regulating valve. The volume of pressurized oil is stored in the accumulator supplying both adjustment pistons. Both pistons are held in the default position by the high pressure oil.

- At the same time the high pressure oil is available at the inlet solenoids of both adjustment pistons.
- VANOS adjustment is carried out by the ECM pulsing the inlet and outlet solenoids to allow pressurized oil to the back side of the adjustment pistons. The surface area on this side of the piston is larger so that the oil pressure is greater and the adjustment piston will move causing the valve timing to change.
- The piston is connected to the adjustment shaft. As the piston moves, the shaft turns the helical splines varying the camshaft sprocket position in relation to the camshafts.

CAUTION! The VANOS system is under high pressure (100 Bar). Consult the Repair Instructions before performing any repairs.

Workshop Hints

When installing the intake camshaft, a visual “sight” is the cam lobes on cylinder number 1 should be pointing horizontally inwards (as shown on the right).

When installing the exhaust camshaft, the cam lobes for cylinder number 1 should be pointing horizontally inwards (refer to Repair Instructions for detailed graphics).

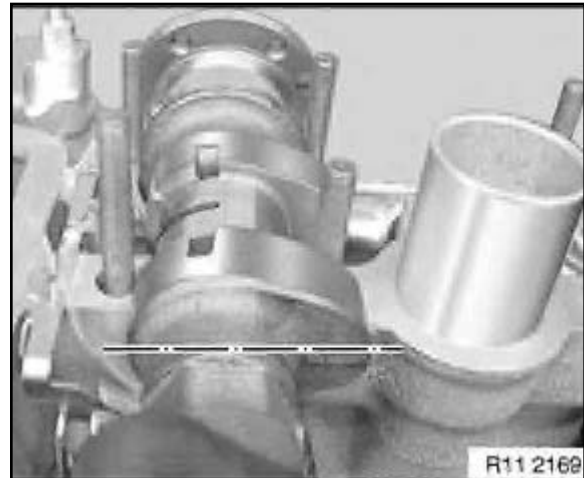

The VANOS function test can be performed by using Special Tools:

#90 88 6 126 411

#90 88 6 126 050

Regulated Compressed Air (2-8 bar)

Refer to the Repair Instructions for the VANOS function test procedures.

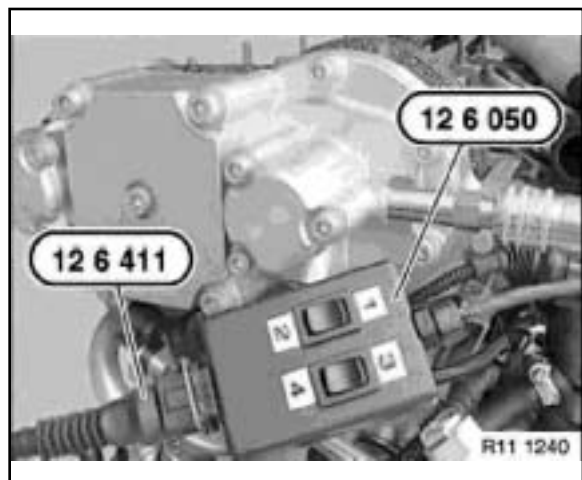

Intake Air Plenum: The intake air plenum is designed for maximum volume required for the S54 engine. The air filter housing and intake manifold are different on the M roadster and M coupé as compared with the M3 due to the under hood dimensions.

The flow characteristics of the one-piece plastic shell is enhanced by internal "funnel" cones to direct the intake air to the throttle housings.

The plenum is attached to the throttle housings by rubber sleeves. A Special Tool (clamp pliers) is required to secure the one-time use clamps.

E46 M3 Shown



11410043.jpg

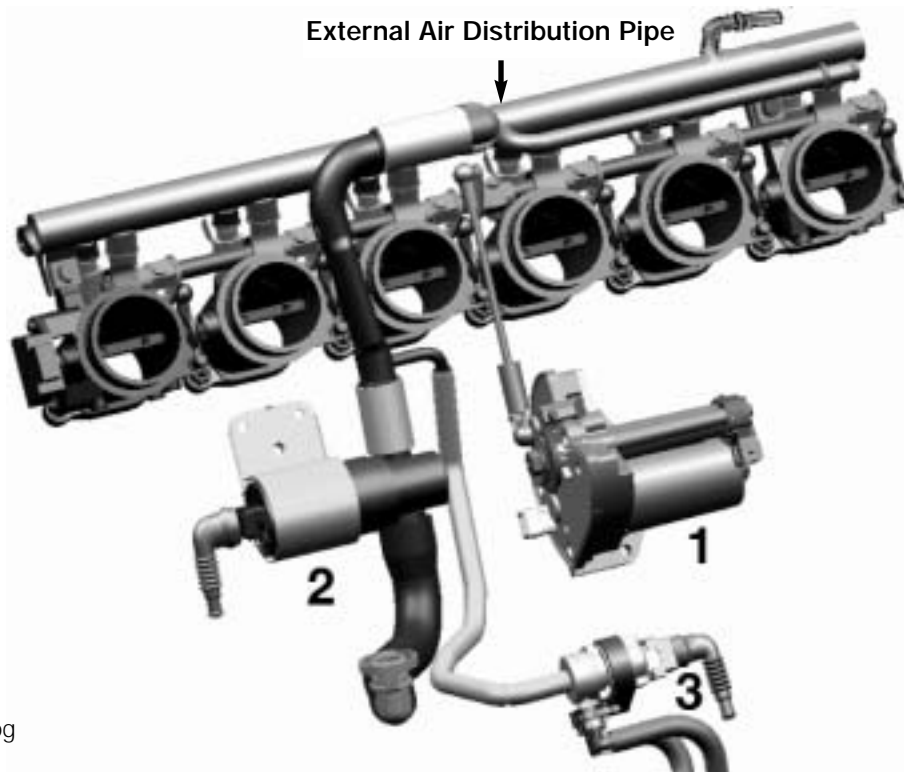

11410044.jpg

Intake Air System: The S54 uses six individual throttle housings operated by an EDR actuator (1 electronic throttle control). For low engine speed (low load) and idling, intake air is provided by an idle air actuator (2). The valve regulates air flow through an external air distribution pipe to the individual throttle housings. Fuel tank vapor intake is regulated by the Evaporative Emission Valve (3).

Refer to the Repair Instructions for the procedure to adjust and synchronize the throttle housings.

Fuel Supply: The fuel is supplied through a Non Return Fuel Rail System. This system is used on the S54 for LEV compliancy.

The fuel supply pressure is controlled by the 5 Bar fuel pressure regulator integrated in the fuel filter assembly. The regulator is influenced by engine vacuum via a hose connected to the external air distribution pipe. The fuel exits the fuel pressure regulator supplying the fuel rail and the injectors. The E46 M3 fuel filter assembly is located under the left front floor area (next to the frame rail).

The fuel return line is located on the filter/regulator assembly which directs the unused fuel back to the fuel tank. The fuel tank hydrocarbons are reduced by returning the fuel from this point instead of from the fuel rail.

The S54 uses Bosch (4 hole plate) fuel injectors. The ECM controls the fuel injectors to regulate the air/fuel mixture.

The injector identification markings are:

1.	BMW Number
2.	Fuel Injector Code
3.	Manufacturing Date (week 06 year 2000)
4.	B+ Voltage Connection

Ignition Coils: The S54 uses "pencil type" ignition coils manufactured by Bremi. The six individual ignition coils are integrated with the spark plug connector (boot).

The coils are removed by lifting the swivel latch connector retainer to release the wiring harness, apply a slight twist and lift the assembly upwards.

NGK DCPR8EKP dual electrode spark plugs are used.

E46 M3 Shown

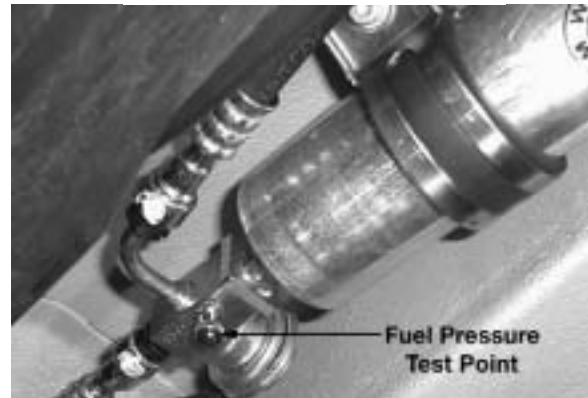

11410045.tiff



11410045.tiff



11410046.tiff



11410047.tiff



11410048.bmp

Clutch Assembly: The S54 clutch assembly is specially designed to transfer the high torque to the driveline and dampen vibrations throughout the rpm range.

The clutch assembly consists of:

Hydraulically Dampened Dual-Mass Flywheel
Diaphragm Type Pressure Plate and Drive Disk

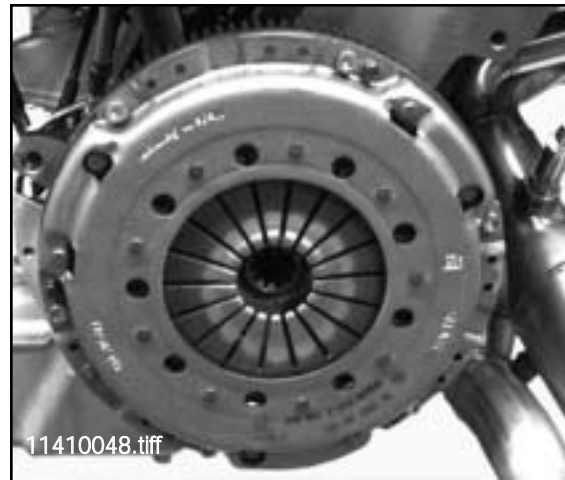

Exhaust System: The US S54 uses two high performance stainless steel exhaust manifolds. The catalytic converters are integral with each exhaust manifold.

Each exhaust manifold/catalyst contains a pre (1) and post (2) oxygen sensor. The sensors require a Special Tool (crescent wrench with swivel adapter) for removal.

The E46 M3 exhaust system is a dual channel up to the muffler. By using the M-mobility kit, additional clearance is provided for the 40 liter half-shell muffler with four outlets. The M roadster and M coupe have separate dual mufflers



E46 M3 Shown



Review Questions

1. What is the valve clearance and at what temperature should it be checked?

Intake _____ Exhaust _____ Engine Temperature _____

2. The crankshaft mounted impulse wheel on the S54 provides:

3. What does the term "cracked" connecting rod mean?

4. What is the function(s) of the oil pumps on the S54?

5. Regarding the Crankcase Ventilation System, what is the purpose of the Check Valve in the oil return line from the intake manifold?

6. When installing the camshafts, they should be installed based on what visual sight?

7. What is unique about the exhaust finger (rocker) shaft?

8. What are the two differences between the intake and exhaust valves?

9. What must be "aligned" with the radial piston high pressure pump when installing the VANOS unit? _____

10. Where is the fuel pressure tested on the E46 M3 and what is the nominal pressure?

